

Development of a donkey-pulled toolframe for weeding

by

Jürgen Hagmann

*Agritex–GTZ Conservation Tillage Project, PO Box 790 Masvingo, Zimbabwe**

Abstract

To alleviate the draft power crisis in Communal Areas of southern Zimbabwe, farmers and a small-scale manufacturer have collaborated to develop a low-cost, light-draft (single donkey) toolframe with attachable tools for weeding, ridge-tying and opening planting furrows. Direct marketing of the implement through a local small-scale manufacturer allows prices to be kept low and ensures local availability. The high demand for the implement indicates that it has a significant potential for large-scale adoption and therefore can contribute to improving the weeding efficiency of smallholder farmers.

Introduction

The Agritex–GTZ Conservation Tillage (ConTill) Project has carried out adaptive and participatory on-farm research in southern Zimbabwe since 1991. All the tillage systems being tested and developed depend on animal draft power, the dominant power source in the smallholder farming sector in Zimbabwe. During the devastating drought in southern Africa in 1992, the cattle population of Zimbabwe dwindled as a result of emergency sales and deaths of animals. In the semi-arid south of Zimbabwe, the effect of the drought was dramatic: 91% of the cattle were lost in one project area, Zaka District in Masvingo Province (CARD, 1994). Cattle losses in other areas were less severe. Donkeys, however, fared much better: in a survey in two other areas, the drought-induced mortality rate of donkeys was found to be 15%, compared with 56% for oxen (Hagmann and Prasad, 1994).

The loss of ox power forced farmers to appreciate donkey power. This resulted in a three-fold increase in donkey prices in one year. However, compared to cattle, donkeys remained an affordable power source. For example, in

1993 a donkey cost 350 Zimbabwe dollars (Z\$) or about US\$ 40, compared to Z\$ 1400 (about US\$ 165) for an ox. The project responded to the draft power shortage by including a donkey power component. Emphasis was given to farmers' priorities, which were harnessing and development of appropriate implements for use with donkeys.

A need for weeding tools

One of the most serious tillage-related constraints in smallholder farming in Zimbabwe is weeding. In the widely practised plow-tillage system, the problem of high infestation with early weeds before planting is tackled through plowing, provided draft power is available. The first weeding run, two to three weeks after emergence, is generally carried out by hand-hoe: farmers rarely use the cultivator because of the risk of damaging or covering crop seedlings. For the second weeding run, six to eight weeks after emergence, if carried out at all, the cultivator is used by farmers who have access to it; other farmers use either a hoe or (very few) a plow.

The adjustable-tine cultivator available locally is rather expensive (Z\$ 900 in 1993, about US\$ 106). In 1992, only 23% of the farmers in Zaka and Chivi District owned one (Table 1). However, cultivators are shared among farmers (mainly within an extended family), which implies that the implement might not be available when it is needed. Both ownership and access are skewed in favour of male-headed households.

Weeding is often delayed because of cultural obligations or labour shortage, and is thus postponed until the school holidays when children can work in the fields. The common results of such delays are higher work requirements and lower crop yields. Chatizwa and Vorage (2000) reported that delaying weeding by only two or three weeks could lead to a 40% increase in work requirements.

* Subsequent address
Jürgen Hagmann, Talstrasse 129, D-79194
Gundelfingen-Wildtal, Germany

Table 1: Ownership of and access to tillage implements by male- and female-headed households in Zaka and Chivi Districts, Zimbabwe

Type of implement	All	Male-headed households		Female-headed households ¹			
	Owner %	Owner %	Access %	No access %	Owner %	Access %	No access %
Plow	88	89	98	2	86	100	0
Cultivator	23	27	48	52	14	33	67
Harrow	19	25	59	41	11	44	56
Planter	7	8	14	86	4	7	93
Ridger	1	1	1	99	0	0	100
Ripper tine	1	1	1	99	0	1	99

¹ Female-headed households comprise de-facto female-headed (husband is absent, working in town) and de-jure female-headed households (not married, separated or widowed)

Source: Unpublished survey of 319 farmers in 1992 by ConTill Project

Weeds are the major factor limiting crop production in Zimbabwe (Chivinge, 1984). As efficient weeding is a critical yield factor, particularly in semi-arid areas, the need for an efficient affordable weeding tool was evident. This need would become more important with the introduction of conservation tillage, whose success depended greatly on efficient weeding (Vogel, 1994).

Development of the toolframe

The major criteria in the development of weeding tools, derived from constraints identified by farmers, were found to be:

- effective in weed control
- available at low cost, affordable for female-headed households in particular
- low draft power requirements suitable for single animals (this increases the total working time per day as animals can be used one after the other—which is particularly important if only two animals are available. In the case of donkeys this can further reduce labour during the weeding operation as one donkey can easily be driven by one person—three persons are normally required to drive cattle)
- low weight of implement, as women do most of the weeding work
- flexibility of the working width, as row spacings vary within fields and differ from crop to crop (eg, groundnuts)
- high durability.

A farmer-driven approach to implement development

The development of the toolframe with weeding tools was not planned or foreseen in the ConTill Project. It emerged out of the need, the initiative and the ideas of farmers, who were then assisted technically in designing their implement. It is therefore a farmer innovation.

The idea was generated when a low-cost tool for ridge-tying was needed, and one farmer brought up the idea of having a very basic beam to carry a semicircular blade. The idea was taken up by the researchers who added basic engineering knowledge and, working with a local engineering workshop, made a prototype. This prototype was given to male and female farmers who tested it and suggested numerous modifications in terms of dimensions, working angles and ergonomics.

After incorporating these suggestions, the implement was tested again by farmers, who came up with another innovation as they fitted other tools to the frame instead of the tying blade: a sweep tine for weeding widely spaced crops; a duckfoot tine for weeding groundnuts; and a cultivator tine for opening shallow furrows for planting small grains, cotton and sunflowers. Farmers shared ideas and came up with suggestions for the design of additional tools. The new designs were tested, improved and refined, together with the local workshop as the future manufacturer in order to reduce costs. A breakage-test and draft power tests followed to ensure technical viability.

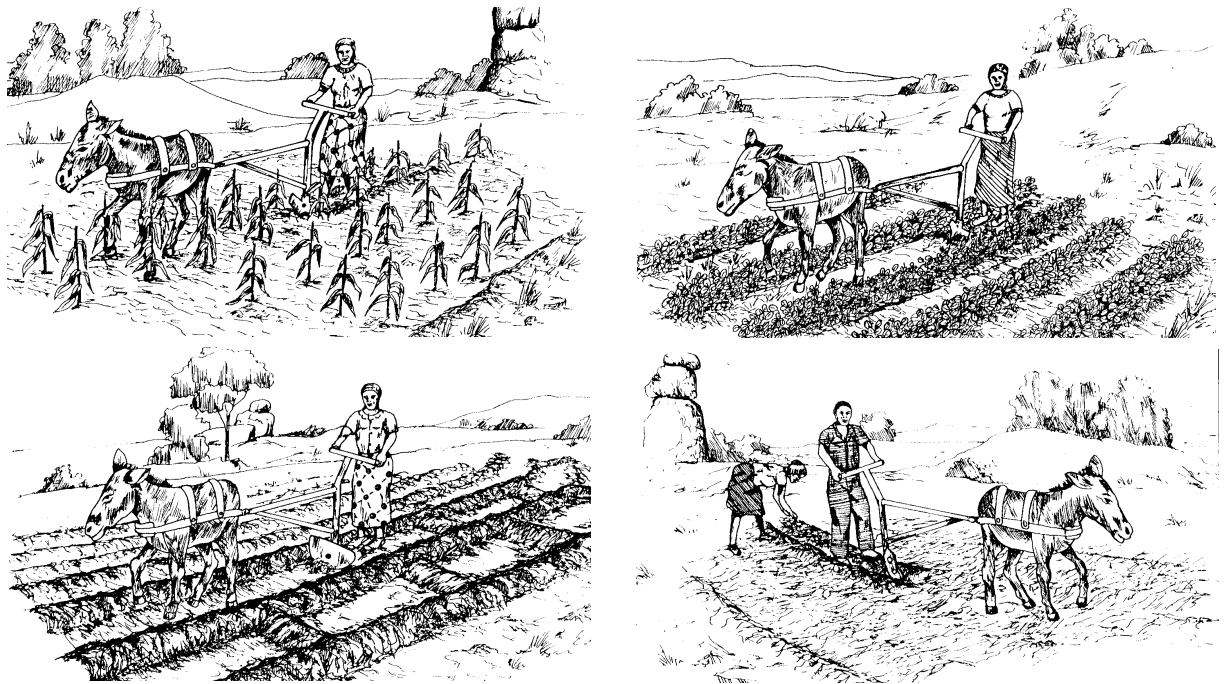

Figure 1: Use of toolframe for weeding maize, weeding groundnuts, ridge-tying and opening of planting furrows

This approach differs markedly from the conventional pattern of implement development, in which engineers first design and test, and only then consult the users and investigate the usefulness through on-farm testing. This new approach proved that farmers themselves have good ideas to develop technologies for their own use. With support from practically-orientated researchers, and local workshops who are able to manufacture for local requirements, these technologies address the needs and requirements of the users and therefore have a high potential for adoption.

Technical design

The design consists of a triangular frame which is hooked onto the back swingles of the donkey harness (Figure 1). A height regulator (such as a wheel) is not required as the swingle is at a constant height. The four different tools are attached to the frame by a single bolt.

The vertical and horizontal bars (A and B) of the frame are made of 25 or 22 mm (3 mm gauge) mild steel tubing (Figure 2). The diagonal crossbar (C) is made of flat bar as it is exposed only to pulling stress, not to distortion. The lower section of the vertical bar (A) is made of solid round bar to give strength to the implement. The working height of the handles is 0.9 m.

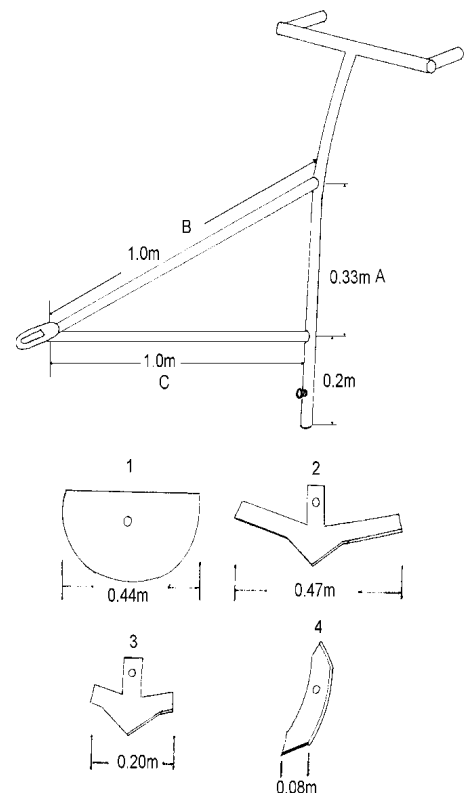

Figure 2: Toolframe with set of cultivation tools
 A: 25 mm mild steel tube (3 mm gauge)
 B: 22 mm mild steel tube (3 mm gauge)
 C: 20 x 5 mm flat bar; D: 25 mm round bar
 1: Semi-circular blade for ridge-tying
 2: Sweep tine for widely-spaced crops
 3: Ducksfoot tine weeder for groundnuts
 4: Chisel tine for opening shallow furrows

Table 2: Draft force and time requirements for weeding tools mounted on toolframe and for the conventional tine cultivator

<i>Tool</i>	<i>Width (cm)</i>	<i>Working depth (cm)</i>	<i>Draft requirement</i>		<i>Time required</i> ¹
			<i>(N)</i>	<i>STD (N)</i>	<i>(h/ha)</i>
Sweep tine	47	6.5	195	80	8.8 ²
Duckfoot tine	20	7.0	191	40	13.2 ³
Ridge-tying blade	44	–	193	80	4.4 ⁴
Chisel tine	8	7.9	188	50	4.4 ⁴
Conventional tine cultivator	68	8.5	717	150	3.9 ⁵

¹ Estimated values, assuming a speed of 0.7 m/s, not considering time for resting or for turning at headlands

² Two runs per crop row spaced 0.9 m apart

³ Crop rows spaced 0.3 m apart in groundnuts

⁴ Assuming a row spacing of 0.9 m

⁵ Pulled by two oxen at assumed speed of 0.8 m/s

The selection of the material was mainly based on availability and price of steel. The total weight of the toolframe with the sweep tine is only 5.9 kg. To keep the working angles constant, the horizontal cross bar should be level during operation and the height of the back swingle must therefore be adjusted accordingly. If cattle are being used, the diagonal crossbar can be extended with a pole which is then attached to the yoke. The sweep tine was adapted from a design used by Chatizwa and Vorage (2000).

In a breakage test, the lower end of the toolframe started bending at a draft force of about 3.1 kN and remained permanently bent at 3.5 kN: this is far above the draft force a donkey can produce. Even when using cattle draft power, the frame is unlikely to break; because of the nature of the tools, the implement does not tend to hook on to an obstacle, but is pulled out of the soil.

Practical experience

Practical experience is based on monitoring about 20 farmers who worked with the implement for one season. As farmers' suggestions were all incorporated in the design, acceptance of the toolframe was high. The low weight made it particularly attractive for women. The major power source was single donkeys but some farmers used cattle (after they extended the beam in order to maintain the working angle) and a few even used human power.

Draft, time and labour requirements

Draft

A draft power test was carried out with the four different tools which can be mounted on the toolframe, and draft requirements were compared to the requirements of the conventional tine cultivator which is manufactured commercially in Zimbabwe (Table 2).

Draft requirements of the four tools were quite similar, and were far lower than the draft requirement of the conventional tine cultivator. The draft requirements of all tools mounted on the toolframe were below 200 N, which is well within the draft capability of a single donkey (Slingerland, 1989). With such low draft force requirements it would be a waste of power to use two donkeys or two cattle. Single oxen could be used, but would require single-ox harnesses which are unknown to farmers in Zimbabwe.

The farmers' idea of using human power was also considered. The beam was extended and a perpendicular crossbar attached to it; two persons, one on either side of this crossbar, could then pull the implement. It proved to be surprisingly easy for two adults to pull the toolframe. This might be a useful option for people without any draft power, as compared to hoe-weeding, the work efficiency would be increased and the strain on humans reduced. Labour would be similar to driving oxen, which also generally involves three persons. Use of human power has become an alternative

Photo: J Hagemann



Photo 1: Toolframe pulled by a donkey and operated by a woman

following the severe loss of draft animals in southern Zimbabwe through drought. Plows pulled by four people were observed on several occasions.

Time and labour

The time requirements listed in Table 2 are in terms of hours per hectare for the work performed. However, for the four weeding tools mounted on the toolframe, the normal farmer practice is to use a single donkey and a single person both driving the donkey and operating the implement; the time requirements are therefore equivalent to (person) labour hours per hectare. The conventional cultivator, on the other hand, is pulled by two oxen driven by three persons, so the human labour requirement is actually 11.7 h/ha.

The sweep tine has a narrow working width, and so requires two runs per crop row, whereas the conventional cultivator, with its adjustable width, weeds throughout the inter-row spacing in one run. Considering labour hours/ha the sweep tine still has an advantage as it requires 8.8 h/ha against 11.7 h/ha for the cultivator. However, considering the working hours of the animals, two oxen with a cultivator would weed one hectare in 3.9 hours, whereas the donkey would require 8.8 hours. Even though two donkeys could be used as single animals after each other, they would not manage to weed one hectare in one day.

Weeding performance

The weeding labour times presented above do not consider in-row weeding; this cannot be carried out with cultivators and is generally done by hand after animal-drawn cultivation.

A sweep tine similar to that mounted on the toolframe was tested in a detailed weeding trial by Chatizwa and Vorage (2000). They concluded that weed control with the sweep tine was as efficient as with the cultivator. Farmers working with the implement also confirmed that sweep-tine weeding was effective in terms of soil surface disturbance, which is an important factor for moisture conservation in semi-arid areas (Ellis-Jones et al, 1993). The sweep tine also enabled weeding to be carried out in fields where stover is left on the surface, and a conventional cultivator could be blocked.

Weeding groundnuts with the narrow duckfoot tine proved very efficient. Farmers emphasised the good 'earthing' effect, which is desirable for groundnuts. As groundnut rows are generally not accurately straight, farmers can rarely weed them with the conventional cultivator (weeding three rows at a time) as it would damage the plants. With the duckfoot, farmers weed row by row and are able to control the implement and avoid plant damage.

For weeding in tied-ridging situations, a general recommendation is to re-ridge. This, however, can only be done once plants are tall enough

not to be covered with soil. Ridge-tying was considered an extra operation and so was often neglected by farmers, until they discovered that it was also an effective weed control measure.

Provided that ridges are regularly spaced, tying with the semicircular blade mounted on the toolframe cuts and scrapes weeds in the furrow (where most weeds grow) and on the flanks of the ridges. The tops of the ridges are then weeded by hoe. This proved to be particularly effective when weeds were small (Photo 2). This farmer innovation has united the extra work of tying for the sake of water conservation with the obligatory weeding operation, and is therefore an important factor for the adoption of tied ridging.

The chisel tine mounted on the toolframe is meant to open shallow planting furrows as required for small grains, sunflowers, groundnuts and cotton. The implement achieved the required depths easily, and farmers were satisfied with the results.

Approach to marketing

The conventional approach to marketing implements in Zimbabwe is through the large implement manufacturers in the country. As they can sell their products with little competition, they are not eager to venture into new products without proof that there is a potential market. The existence of a market can hardly be proven without an available product. Thus, many innovative implements in Zimbabwe have ended up in the scrapyards of the designers.

The conventional marketing approach would clearly not be successful for the new toolframe, so a decentralised approach was developed. The workshop which was involved in the design of the toolframe was able to manufacture for the local market. The owner of this workshop was also willing to market the implements on his own. Several merchants from rural areas who frequent his workshop showed interest and started to sell the implements in their own stores. To reach a wider group of communal farmers, a brochure was produced, with descriptions in vernacular and simple drawings (an example is shown in Figure 1) of the toolframe and other implements designed by the ConTill Project. These have been designed to be distributed through various outlets and through agricultural extension workers.



Photo 2: Effect of ridge tying as a weeding operation. Weeds in the furrow and on the flanks are controlled with the tying operation

As most of the farmers in the province come to the provincial capital at least once a year, they have the opportunity to buy the implements direct from the manufacturer without price mark-ups (see Table 3).

The price of the toolframe set was US\$ 21 (Z\$ 175) in 1994. This was about the sale price of two bags of maize (then Z\$ 90 per bag). The implements therefore appeared fairly affordable for most households. Yield increases due to more timely weeding should justify the investment. For comparison, at the same time, 'traditional' cultivators cost US\$ 106 (Z\$ 900) and mouldboard plows cost US\$ 67 (Z\$ 570).

Local blacksmiths in the communal areas could be another source of implements. However, after farmers took the designs to them and ordered implements, it turned out that the prices charged by blacksmiths were more than 50% higher. Also the quality generally of the implements produced by blacksmiths was lower than those made at the workshop in Masvingo.

The potential for large-scale adoption of the toolframe with the weeding tools was shown by the initial demand. Without any active promotion, more than 100 toolframes were sold through the workshop in Masvingo in the first agricultural season.

Conclusion

The result of the farmer-driven approach to the development of tools is an implement which suits farmers' needs and has a high potential for large-scale adoption. The low draft power requirement which makes the implement particularly suitable for single-donkey use addresses the drastic shortages of animal draft

power resulting from a devastating drought. A low price has been achieved, partly due to the direct marketing system of the small-scale manufacturer. Provided their willingness to invest in farming in a high risk environment is sufficient, the implement should allow resource-poor households to improve their weeding efficiency through low-cost mechanisation.

Promotion of donkey tools should go hand in hand with improvements in harnessing and management of donkeys. In general, these are considered poor in the communal areas of Zimbabwe. The use of single oxen in combination with light draft-power implements such as the toolframe, and even the use of human power, are other aspects to consider in future work to alleviate the draft power crisis.

The contribution of new implements to an increase in crop production depends more on the timeliness of operations such as weeding than on the actual tool itself. Therefore, the tool must always be seen in the context of timely and adequate availability of draft power and labour, issues which often are more of a socio-economic/cultural than technical nature.

Acknowledgements

The author would like to express his appreciation to Mr E Gloss (Auto and Engineering, Masvingo) for his great interest and technical competence in implement development, Mr O Gundani who secured the close link between researchers and farmers through his dedicated field work, Mr R Shuva for the drawings and the cooperating farmers for their ideas and enthusiasm.

References

- CARD, 1994. *Report on a baseline agro-socio-economic survey in Zaka District, Masvingo Province*. Coordinated Agricultural and Rural Development Programme (CARD), Masvingo, Zimbabwe.
- Chatizwa I and Vorage R, 2000. Research on weed control using animal power undertaken by the Institute of Agricultural Engineering, Zimbabwe. In: Starkey P and Simalenga T (eds), *Animal power for weed control*. Animal Traction Network for Eastern and Southern Africa (ATNESA) and Technical Centre for Agricultural and Rural Cooperation (CTA), Wageningen, The Netherlands. ISBN 92-9081-136-6
- Chivingo O A, 1984. The role of herbicide technology on the small scale farms in Zimbabwe. *Zimbabwe Agricultural Journal* 81(3).
- Ellis-Jones J, Twomlow S, Willcocks T, Riches R, Dhliwayo H and Mudhara M, 1993. Conservation tillage/weed control systems for communal farming areas in semi-arid Zimbabwe. 1161-1166 in: *Proceedings of Crop Protection Conference (Weeds 3) held November 1993*, Brighton, UK. British Crop Protection Society, London, UK.
- Hagmann J and Prasad V, 1994. The use of donkeys and their draft performance in smallholder farming in Zimbabwe. pp. 21–30 in: *Project Research Report 11*, Conservation Tillage Project, Institute of Agricultural Engineering, Harare, Zimbabwe. 30p.
- Slingerland M A, 1989. Selection of animals for work in sub-Saharan Africa: Research at ICRISAT Sahelian Centre. pp. 203–210 in: Hoffman D, Mari J and Petheram R J (eds), *Draught animals in rural development*. Proceedings of an international research symposium held at Cipanas, Indonesia 3–7 July 1989. ACIAR Proceedings Series 27. Australian Centre for International Agricultural Research, Canberra, Australia. 345p. ISBN 1-86320-003-7
- Vogel H, 1994. A need for integrated weed management in smallholder conservation farming. pp. 1–20 in: *Project Research Report 11*, Conservation Tillage Project, Institute of Agricultural Engineering, Harare, Zimbabwe. 30p.